

# EM-231A CONTROL UNIT FOR DOORS AND HATCHES



## FEATURES:

- supply from 230Vac
- for 24Vdc motors
- motor current limit
- safety reverse
- end switch inputs
- pulse encoder input
- radar input
- remote control option
- CE marked

EM-231A is designed for door and hatch controlling. Control unit includes the 230Vac isolated mains power which converts the voltage to the 24Vdc for control electronics and door motor. Motor can be a normal low voltage DC-motor. In the basic operating mode the end stop can be realized with current limit or end switches. More sophisticated behaviour can be achieved with pulse encoder feedback. In this pulse mode the controller can be learned with a push of a button. After the controller has learned the stroke length it executes the open/close cycles smoothly anticipating the end stops with slow down ramps. In all operating modes the current limit is active and ready to stop the motor if the adjusted value is exceeded. If desired a safety reverse action can be set to follow this current trip. With safety reverse active eg. a person who is in the way of a closing door will cause the motor to reverse and door to open. Unit includes the inputs for end switches, door radar, OPEN/CLOSE buttons and for pulse encoder. Additionally there are inputs also for emergency drive and learning, and a serial connector for an interface unit. An optional remote control feature can be achieved with a remote control unit and by plugging a receiver hybrid (EM-A6) in to its holder. Speed, ramp times and current limit can be adjusted with trimmers. Operating mode, safety reverse and learning can be enabled and determined with dip switches. To achieve more sophisticated operation and customized settings the serial interface unit EM-236 can be connected to serial connector. With serial interface user can adjust the approaching speed, acceleration zone length, approaching current limit and radar off delay.

EM-231A is housed to a plastic IP30 (IP65) ABS(PC) housing. Unit is CE-marked.

## TECHNICAL DATA

Supply voltage	230Vac / max. 100W
Fuse	T1A 20x5mm
Output voltage	nom. 24Vdc
Output current	1.5A (U <sub>out</sub> =24V) 3A (U <sub>out</sub> =18V) 30% duty
Current limit	0-4A
Ramp time	0-2s
Speed range	0-100%
Pulse frequency	max. 1000Hz/50/50%
Pulse length	min. 0,5ms
Input signals	4-30V=ON / 0-1V=OFF
Input impedances	10kohm
Aux. outputs	Total current 50mA 24V max.40mA 5V max. 40mA
Fault output	NPN open col. (100mA)
Remote Control	433Mhz typ. range 10m
Housing ABS(PC)	130x130x60 / IP30 (IP65)
Operating temp.	0-50°C
Mains isolation	1000V

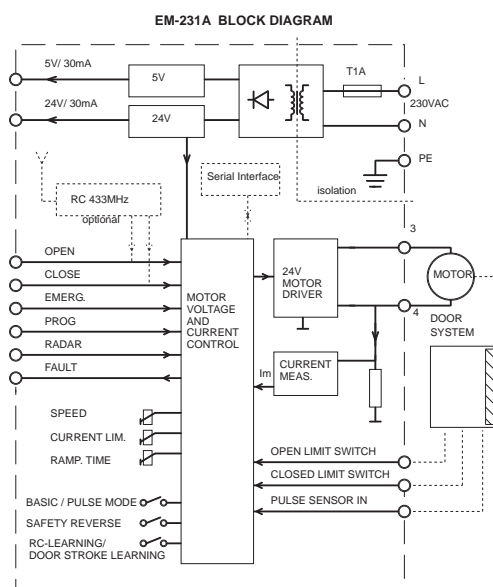

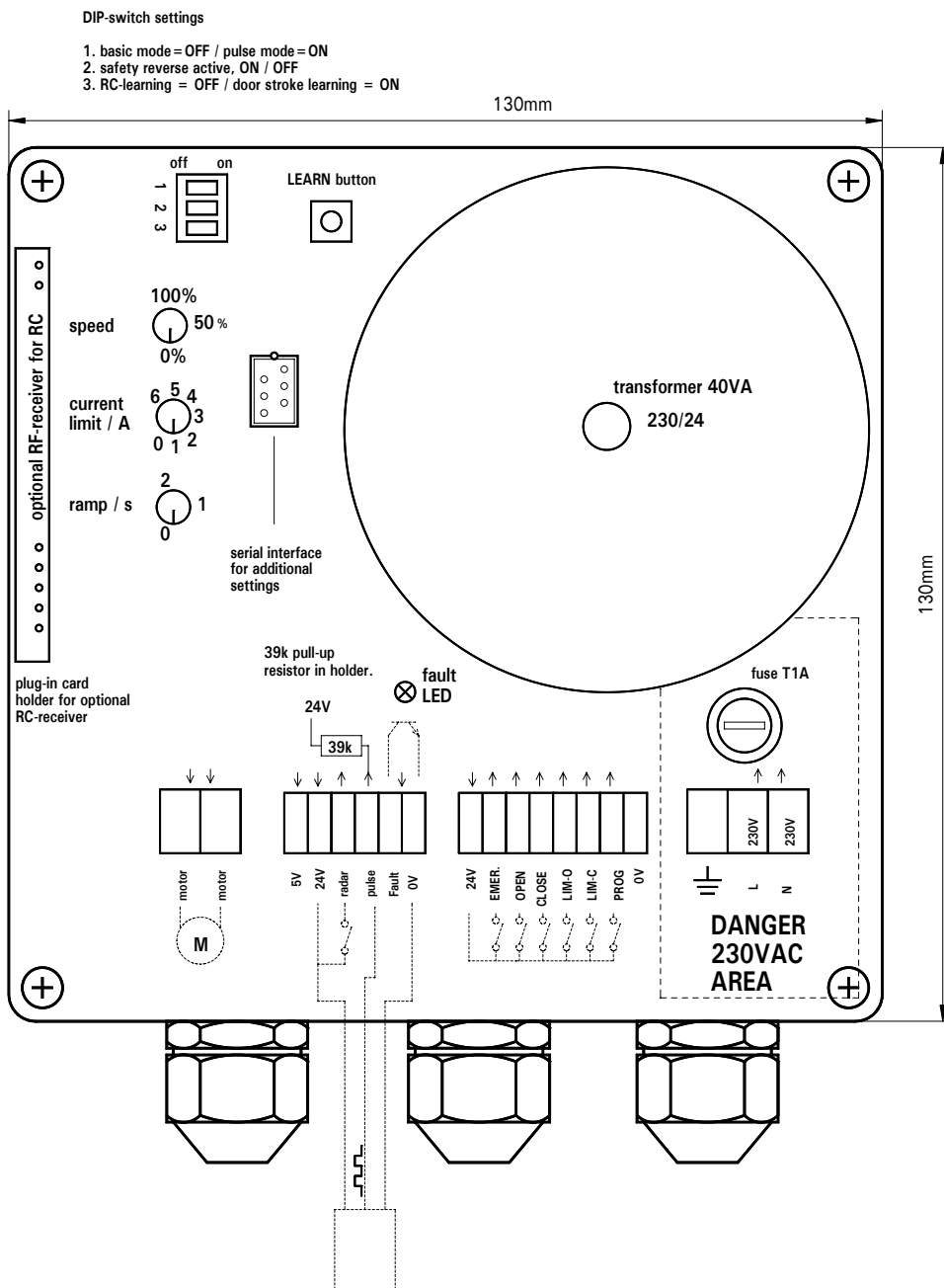

**CONNECTIONS**

Make sure that the mains supply is not on when making the connections. NOTICE! that there is 230Vac area in this device. Do not let any other than 230Vac wiring in this area. Do not use the same inlet for others than 230Vac cabling. Device has a terminal for connecting the protective earth (PE). It can be used if there is need for leading the PE to the auxiliary devices.

Check that the current consumption of limit switches, pulse encoders and radar do not exceed the max. current feed capability of 24/5V auxiliary outputs (altogether 50mA). Control inputs operate with positive 4-30Vdc signals, with input impedance of 10kohm. The pulse encoder input can be configured for PNP or NPN signal, that is with up or down pullin transducers. Eg. Hall-transducers are mostly of the NPN-type (pull down), in that case the 39kohm line pull up resistor should be in its holder.

**SETTINGS**

Set the desired operating mode with dip-switch (see the page OPERATING MODES). Adjust the speed, ramp time and current limit with trimmers. If you need more detailed setting, attache the EM-236 serial interface to this control unit, and you have access to a lot wider range of parameters (see the page 3 OPERATING MODES). Especially in pulse mode can be achieved better adjustability with EM-236. The safety reverse can be enabled with dip switch 2. When safety reverse is enabled, the motor will automatically reverse after exceeding the adjusted current limit eg. in case of encountering an obstacle during close run.

**LEARNING**

In pulse mode the control device must be learned for the right driving cycle of a door or hatch. This is done by switching the dip-switch 3 to ON-position and pressing the learn button. After this the device will execute the learning cycle (see page 3 OPERATING MODES). After this the functionality can be adjusted with parameters. NOTICE. Learning can be triggered also with a 4-30V signal to the prog. terminal.

**RC-learning (if the optional RC receiver EM-A6 is attached)**  
To be able to remotely control the device it has to be learned the code of the specific remote control unit. Set the dip-switch 3 to OFF position, keep the learn button pressed and press the remote controllers OPEN button so long that the door is started (about 1s). Afterwards return the dip switch 3 to ON position. Also in this case the prog. input can be used instead of the learn button. NOTICE. Remote control will not work at the same time as the interface unit is connected to the control unit.

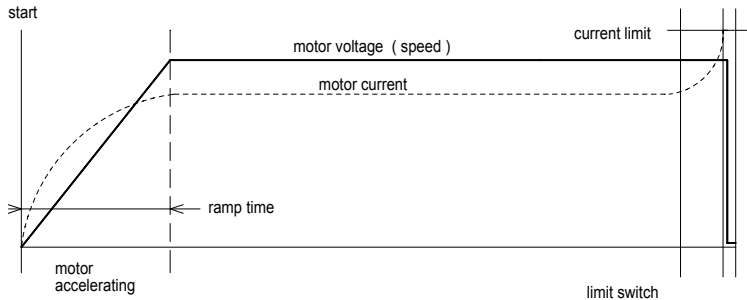

**OPERATING MODES OF EM-231A**

**BASIC MODE with current trip**

- open/close command starts motor
- motor accelerates with ramp
- motor runs with adjusted speed
- door meets the end point and motor current starts to rise until it exceeds the current limit, which causes the motor shut down
- the current limit also shuts down the motor, if the door meets an obstacle during drive cycle
- the action is same to both directions
- the safety reverse function is not available in this mode
- Notice ! In this mode there should be some kind of bumper in the end of stroke to smoothen up the end stop.

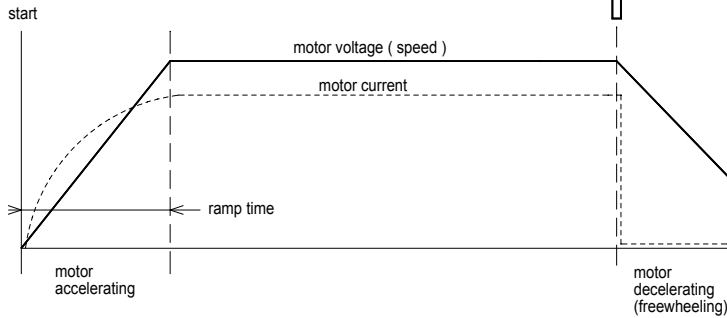

**BASIC MODE with a limit switch**

- open / close command starts motor
- motor accelerates with ramp
- motor runs with adjusted speed
- door reaches the limit switch and motor will be shut down.
- door slides with decelerating speed to the end of stroke.
- If door meets an obstacle inside stroke, the current limit will shut down the motor.
- If safety reverse function is activated, and current limit is exceeded during close cycle, the door will stop and then start automatically to open direction.

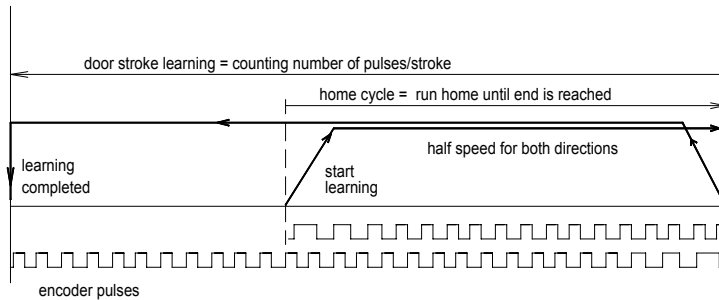

**PULSE MODE**

In this mode the device uses pulse counting to control the stroke length of the door. Recommended pulse rate is 200-10000 pulses/stroke, and pulse frequency should be below 1000Hz

When system is taken in use for the first time, run the "learning" routine first:

- push learning button
- motor starts to run at approaching speed until the door reaches the end of stroke.
- Then motor starts automatically to opposite direction. During this calibration cycle the device counts the number of pulses of the full stroke and in the end of this cycle the motor stops and the number of pulses is stored to memory.

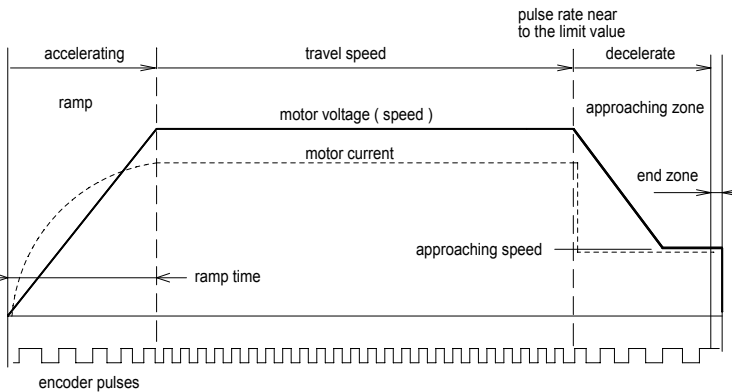

After learning has been done the system is ready to run

- open/close command starts the motor
- motor accelerates with "ramp"
- motor runs at "travel speed"
- door reaches the edge of "approaching zone", motor speed is changed to "approaching speed" and current limit to "appr. current lim."
- motor is stopped if:
  - current limit is exceed
  - pulses stop coming
- if motor stops inside the "end zone", the device will reset the pulse counter and is ready for re-start
- but if shut down happens before counter has reached the "end zone" value, the device will go to "limb mode" and next cycle will be driven with approaching speed.
- If "safety reverse" setting is activated and the door meets an obstacle during closing cycle, the door will stop and reverse (open) automatically.

**SETTINGS & PARAMETERS**

**Trimmer setting ranges**

- "ramp" 0-2s
- "travel speed" 0-100%
- "current limit" 0-6A

**Automatically set parameters**

- "approaching speed" 50% of travel speed
- "approaching current limit" = current limit
- "approaching zone" 10% of full range
- "end zone" 2% of full stroke
- radar input make off delay 5s.

**Dip switch settings**

1. Basic mode = off / Pulse mode = on
2. safety reverse active on / off
3. RC-learning = off / door stroke learning = on

**ADDITIONAL SETTINGS VIA SERIAL INTERFACE**

The next settings are possible to set individually if serial interface unit is connected to device. If serial interface is selected to be active ( param.1) the interface unit will over write trimmer- and automatic settings. With interface unit it is also possible to monitor the current and pulse counter values during drive.

	default settings
1. serial interface active 0=no / 1=yes	0
2. "travel speed" 0-100% ( 0-100 )	100
3. "approaching speed 0-100% ( 0-100 )	50
4. "current limit" 0-6A ( 0-60 ) 0.1A/step	30
5. "approaching current lim." 0-6A ( 0-60 ) 0.1A/step	30
6. "approaching zone" 3-30% of full stroke ( 3-30 )	10
7. "end zone" 1-5% of full stroke ( 1-5 )	2
8. radar input off delay 0-255s. ( 0-255 )	5
9. "ramp" 0-2s ( 0-20 ) 0.1s/step	10

**MONITOR VALUES**

1. motor current 0-60 ( 0-6A )
2. pulse counter value 0-65535