

# EM-366 BRUSHLESS DC-MOTOR DRIVER 12-48V 30/25A

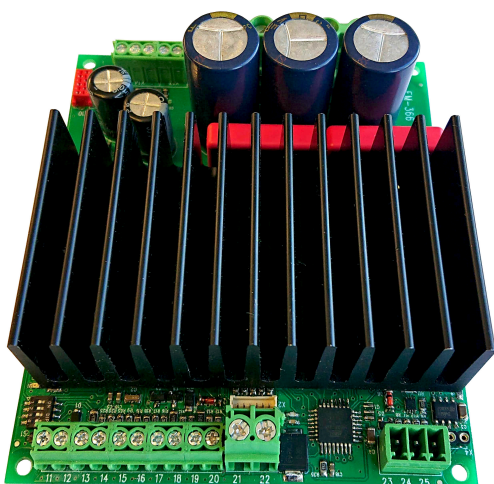

## FEATURES

- Only for motors with Hall sensors
- Speed and torque adjustment
- Open/closed loop modes
- Regenerative braking option
- Braking resistor output
- Fan control output
- For motors up to 200W @12V  
300W @ 24V and 400W @ 48V
- Current limit and trip
- Indication output option
- Good efficiency
- Low EMC emissions
- DIN-rail mountable

- Firmware v1.0 or later
- Rs-485 Modbus control option
- Firmware v1.7 or later
- Added input functions, par. 11,13, 20
- Added power on mode, parameter 15

## GENERAL

EM-366 is brushless DC-motor driver with hall sensor feedback. The unit has a mosfet power stage with good efficiency and it meets also today's EMC requirements. The driver can be used with 120° commutation. This driver has true 4Q power stage, and it makes possible to use regenerative braking. In this braking method the supply voltage rises, this voltage rising can be controlled with braking resistor. If uses battery supply then the braking energy can be leaded back to battery and braking resistor will not be needed. The unit has the basic digital command inputs like direction, start/stop, disable, speed-2 activation and there is analog inputs for speed and current control. EM-366 has PNP output for fault indication use. Several input and output functions can be modified with parameters. Driver includes overvoltage, undervoltage and overtemperature protections. These fault situations are indicated with fault on-board LED and indication output. Optionally this device can be controlled with Rs-485 interface with modbus

There are two control options for speed. Direct control (open loop) sets motor voltage in proportion to control voltage as with a standard DC-motor. Closed loop uses hall sensor feedback for speed control, this mode offers good speed regulation. Start and stop ramps work in both mode. Speed adjust range, closed loop rpm range and ramps can be set with parameter. Analog input are filtered so that there can also use PWM signal for control speed and current.

Setting can be done digitally with EM-236 interface unit or with Emen-Tool lite program installed in PC and EM-328 adapter cable. Parameters stored into nonvolatile memory of device. This interface unit can also be monitored the current and rpm of motor.

Device can be installed in DIN-rail base and some enclosure options are also available.

## TECHNICAL DATA

Supply voltage 12-48Vdc (11-58Vdc)  
 Overvoltage shut down 60V  
 Undervoltage shut down 10V, start up 11V  
 Idle current typ. 30mA  
 Max. current 30A cont. (@ 24Vdc, Tamb. 25 °C)  
 Max. current 25A cont. (@ 48Vdc, Tamb. 25 °C)  
 above currents @50°C Tamb. if fan is used.  
 Max. current peak 60A (max. 2s)  
 Thermal losses 10W@20A 20W@30A  
 Max. brake output current 10A  
 Pwm frequency typ. 16kHz  
 Overtemperature shut down 90°C  
 Current limit setting 1-60A (step 1A)  
 Current limit analog scale 0-5V = 0-75A  
 Logic level of digital inputs  
 "off" = 0-1V or open / "on" = 4-30V  
 Input impedance of logic inputs 10k  
 Response time of digital input 2ms  
 Analog input range 0-5V up to 0-10V  
 Input impedance of analog inputs 100k  
 Input filter of analog input 100Hz  
 Fault outputs NPN max 50mA (5V / 12V)  
 Fan output NPN max. 100mA (12V)  
 Fan output "on" > 55°C / "off" < 50°C  
 EMC measured for industrial environment.  
 PCB material flammability class UL94V-0  
 Dimensions 108x91x37mm  
 Weight 270g

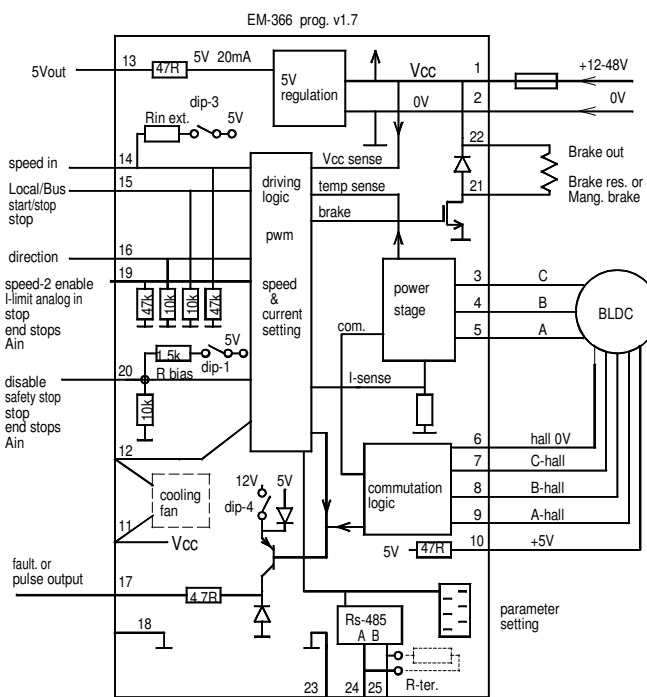

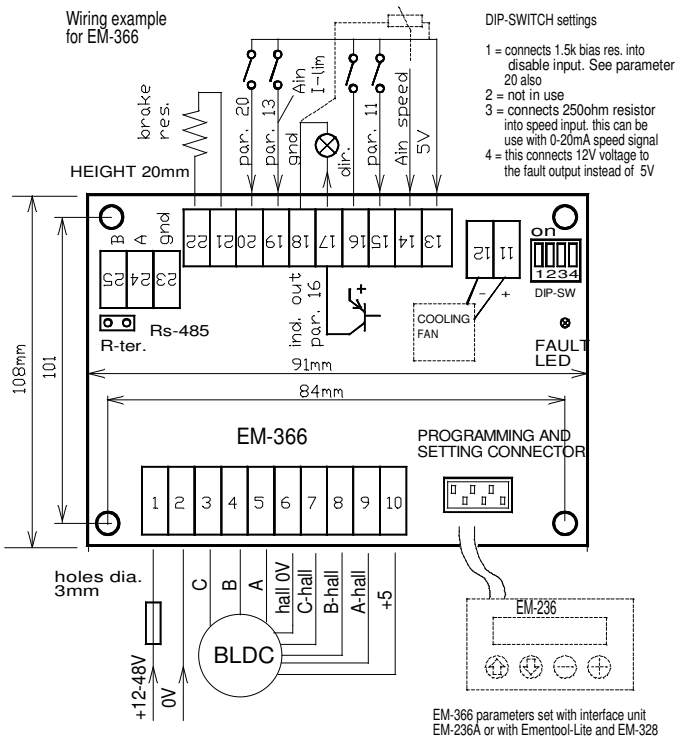

TAKE IN USE

Nominal operating voltage 12-48Vdc ripple less than 20%  
An external supply fuse is recommended (2-40A)

Be sharp when connect motor wires, because there is lot of combinations. If motor takes much current or run roughly then change order of hall-sensor and try again

Default settings are in brackets in parameter list. when you uses these default paramets you need only potentiometer to test motor.

When power turn on the device can be ready to run or disabled  
In ready to run mode driver starts directly if speed is set .  
In disable mode speed must be set to 0 before start is possible.  
See parameter 15

In example picture beside there all input connected, but device work also with less wiring, you can start only with speed signal ( par. = 0 ). More wiring option on application sheet.

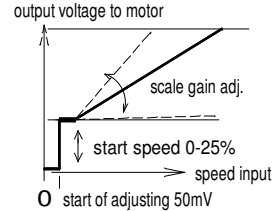

In some application load can be generated energy back to drive, when slowing down speed. Then there needed braking resistor, which absorbed extra energy.  
NOTICE that the parameter 18 has to be set about 10% higher than unloaded voltage of power supply.  
In the battery powered application the resistor not need, because the battery absorb the regenerated energy.

SETTABLE PARAMETERS ( prog. 366 v1.7 )

1. mode: open loop =0 / closed loop=1 ( 0 )
2. closed loop range 0-4 ( 3 )  
0=15000rpm, 1=7500rpm, 2=5000rpm 3=2500rpm 4=1500rpm  
above ranges is for 4-pole motor ( 2 pole pair ). For the motor with higher number of poles the max rpm is smaller in the ration of number of poles
3. start ramp 0-5s / 0-50 ( 10 )
4. stop ramp 0-5s / 0-50 ( 5 )
5. I-trip delay 0.01-2.5 / 0-255, 0=I-trip, disabled ( 200 )
6. scale start speed 0-25.5% / 0-255 ( 0 )
7. scale gain 0-2.55 / 0-255 ( 200 )
8. Load compensation ( Rxl ) adjust 1-200 ( 5 )  
or in closed loop mode dynamic P-factor
9. closed loop dynamic I-factor 1-200 ( 10 )
10. regen. braking current limit 2-40A / 2-40 ( 25 )
11. Input PIN 15 options ( 0 )  
0 = open or "low" = Local / "high" = Bus  
1 = open or "low" = Bus / "high" = Local  
2 = local/Bus control selection with Bus only  
3= local only and pin 15 as start/stop  
4= local only and pin 15 as stop input  
5= local only and pins 15 and 16 impulse input  
6 = local only and pin 15 as end stop BW
12. current limit 0 / 1-40A / 1-40 ( 20 )
13. Input PIN 19 options 0-100 / 0-100 ( 50 )  
0= input is I-lim analog input 0-5V  
1 = stop input  
2= end stop FW  
3 = end stop BW  
4 = analog input  
10-100 = speed-2 enable and par. = speed-2
14. I-trip reset mode ( 0 )  
0= only with disable pin  
1 = disable or with speed input change 0 to up  
10-200 = timer reset with 0.1s steps = 1-20s.
15. Start up mode when power on & over temp. reset options ( 1 )  
0= ready to run when power on & over temp. reset disable input  
1 = ready to run when power on & over temp. res. with speed 0 to up  
2 = disabled when power on & over temp. res. with speed 0 to up  
10-200 = ready to run when power on & over temp. reset with timer reset time 0.1s steps = 1-20s.
16. PIN 17 output function ( 1 )  
0 = overtemp. and overvoltage  
1 = overtemp, overvoltage, and I-trip  
2 = overtemp, overvoltage, I-trip and overcurrent  
3 = reserved for pulse output use, see param 17  
4 = same as the LED on circuit board
17. pulse output divider 1-20, enabled only if param. 16=3 ( 1 )  
1 = 1pulse/round  
2 = 1pulse/ 2round...  
...  
20= 1pulse/ 20round
18. brake res. threshold (=overvoltage) 15-60V / 15-60 ( 35 )
19. brake output mode and braking mode 0-3 ( 0 )  
0 = output active if param. 18 value exceed and brk. mode "regenerative"  
1 = output active if param 18 value exceed and brk. mode "freewheel"  
2 = output active when "run" and braking mode "regenerative"  
3= output active when "run" and braking mode "freewheel"
20. Input pin 20 options ( 0 )  
0 = disable ( and reset )  
1 = safety switch stop with wiring monitor ( closing contact )  
2 = stop input  
3 = end stop FW  
4 = end stop BW  
5 = analog input
21. Baud rate 0...5 ( 3 )  
0= 9600, even, 1 stop, 3= 19200, even, 1 stop  
1= 9600, odd, 1 stop 4= 19200, odd, 1 stop  
2= 9600, none, 2 stop 5= 19200, none, 2 stop
22. Modbus Address 1...247 ( 1 )

CONTROL INPUTS

SPEED input is a analog control input for speed setting.  
Set signal can be between 0-5V and 0-10V  
Speed scaling can be made with parameter 6 and 7.

PIN 15 can be used to select control source LOCAL / BUS  
Local control with card terminal or Buscontrol with Rs-485  
This Input has also another options which can be set with parameter 11

DIRECTION input is a digital input. It changes the rotation direction. It uses automatically stop/start ramps during change.

INPUT PIN 19 is a multifunction input it can be set with 13.  
This can be worked as analog CURRENT LIMIT input, SPEED-2 activation input or different type of STOP inputs

INPUT PIN 20 is a multifunction input, it can be set with par. 20 This input can be worked as SAFETY SWITCH input, DISABLE input or different type of STOP inputs

SAFETY SWITCH option including also line monitor for safety switch. If the line resistance is too high the device gives warning

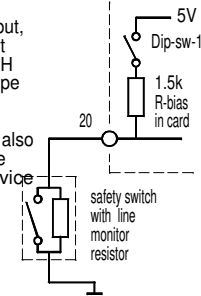

OUTPUTS

FAULT / PULSE OUT This output modes can be set with parameter 16. There is some options when output will be activate.  
The special mode is pulse output, in this case output gives out rpm-pulses which can scaled with parameter 17

BRAKE output can used to control magnetic brake of motor or switch a braking resistor in regenerative braking. the mode can be set with parameter 19  
Recommend brake resistor , Wirewound 10-50W  
Resistance 4.7R at 12V, 10R at 24V and 22R at 48V

Rs-485 port can be used to control device with Modbus protocol  
This port has own guide sheet " Modbus register definitions for EM-356A"

MONITOR VALUES

1. current 1A / digit
2. braking current 1A / digit
3. hall sensor freq. 0-255Hz
4. operation voltage 0.1V / digit
5. pwm 0-255 ( 255 = 100% )

INDICATIONS.

Continuous light: Over. temp. or over voltage or disable  
Fast blinking : current limit exceeded  
Short blinks: shutted down by overcurrent ( I-trip )  
Long blinks: safety switch wire fault  
Slow blinking: shutted down by safety switch

Fault output: ( Pin-17 PNP open collector output )  
Overtemperature, Overvoltage, Undervoltage.  
This indicates also I-Trip if parameter 16 is set to = 0